

MACHINERY

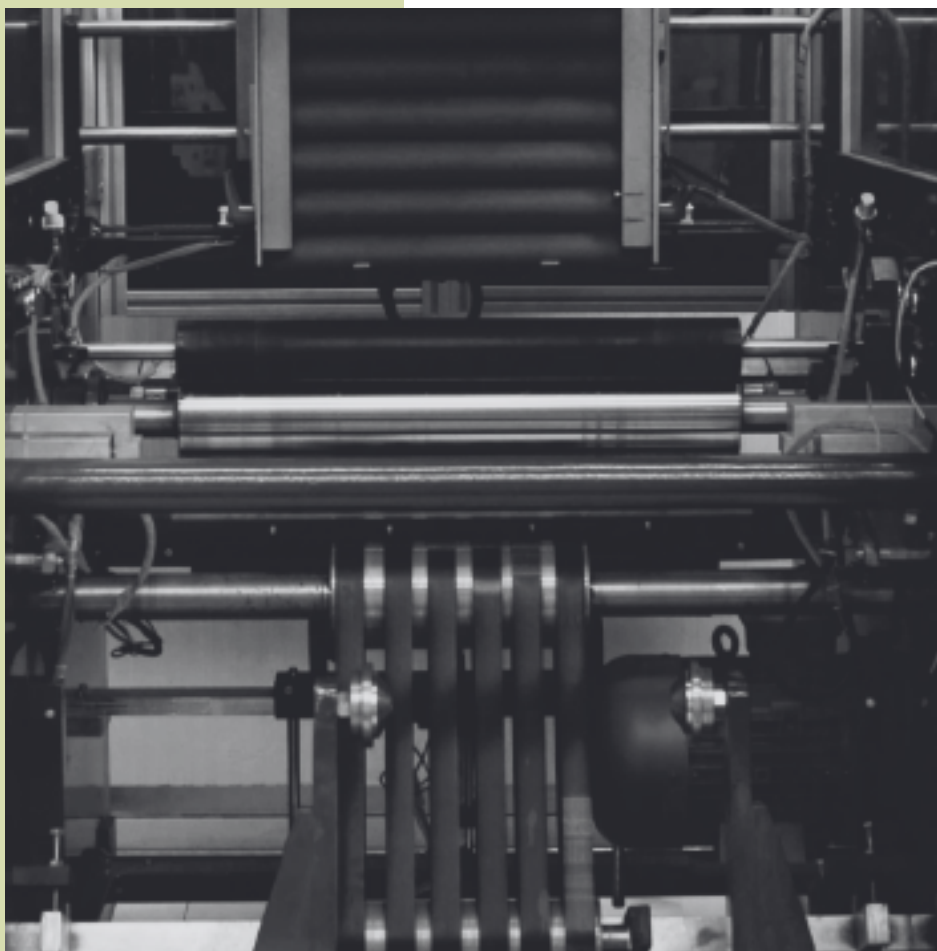

STRETCH FILM



E - PSK 150

Otomatik Streç Sarma Makinesi

- Tam otomatik sistem
- Otomatik masura deęiřtirme
- Otomatik tek tuřla Jumbo rulo saę-sol ayarı
- 7 inch dokunmatik PLC ekran (Omron)
- Sürücü motor: Omron
- Elektrik aksam: Schneider Electric
- Pnömatik sistem: Airtac
- Elektronik kenar kontrol sistemi
- Masura sonu bitiş sensörü
- Kolay ayarlanabilen masura haznesi
- Rulo sarma sonunda sıcak tel ile kesim

Automatic Stretch Rewinder Machine

- Fully automatic system
- Automatic core rewinding and Exchange
- Automatic Jumbo roll right - left control unit with button
- 7 inch touch screen (Brand: Omron PLC)
- Motor dirve: Omron
- Switch gears: Schneider Electric
- Pneumatic system: Airtac
- Electronic edge control system
- Core presence sensor
- Easy to use core reservoir
- At the end of rewinding for a roll, cutting process with hot wire

TEKNİK ÖZELLİKLER / TECHNICAL SPECIFICATIONS

- Makine Hızı / Machine Speed: 1080 m/dk / (meter/min)
- Merdane Geniřlięi / Roller Width: 650 mm
- Kullanılabilir Jumbo Geniřlikleri / Jumbo Width Range: 300 - 520 mm
- Kullanılabilir Jumbo Aęırlıkları / Jumbo Weight Range: 65 kg max.

- Masura Haznesi / Core Reservoir (Ø50): 65 Adet / Pcs
- Ana Motor / Engine: 4 kW AC
- Kullanılabilir Masura Çapları / Core Diameter Range: Ø38 - Ø50 mm
- Sarılmış Rulo Çapı / Rewinded Product Diameter: Ø130 mm max.

MACHINERY

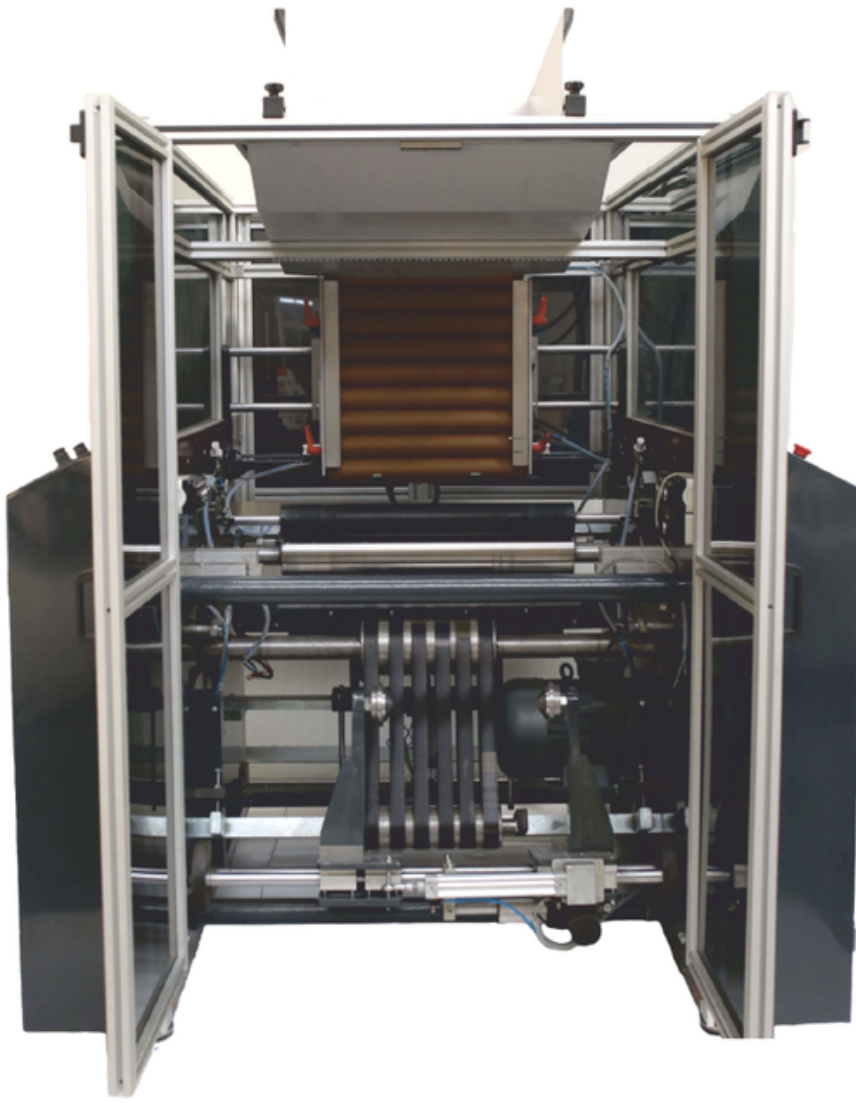

E-PSB 500

Otomatik Streç Sarma Makinesi

- Tam otomatik sistem
- Otomatik masura deęiřtirme
- Otomatik tek tuřla Jumbo rulo saę-sol ayarı
- 7 inch dokunmatik PLC ekran (Omron)
- Sürücü motor: Omron
- Elektrik aksam: Schneider Electric
- Pnömatik sistem: Airtac
- Elektronik kenar kontrol sistemi
- Film ve masura sonu bitiş sensörü
- Kolay ayarlanabilen masura haznesi
- Rulo sarma sonunda sıcak tel ile kesim

Automatic Stretch Rewinder Machine

- Fully automatic system
- Automatic core rewinding and Exchange
- Automatic Jumbo roll right - left control unit with button
- 7 inch touch screen (Brand: Omron PLC)
- Motor dirve: Omron
- Switch gears: Schneider Electric
- Pneumatic system: Airtac
- Electronic edge control system
- Film and core presence sensor
- Easy to use core reservoir
- At the end of rewinding for a roll, cutting process with hot wire

TEKNİK ÖZELLİKLER / TECHNICAL SPECIFICATIONS

- Makine Hızı / Machine Speed: 1200 m/dk / (meter/min)
- Merdane Geniřlięi / Roller Width: 720 mm
- Kullanılabilir Jumbo Geniřlikleri / Jumbo Width Range: 300 - 520 mm
- Kullanılabilir Jumbo Aęırlıkları / Jumbo Weight Range: 75 kg max.

- Masura Haznesi / Core Reservoir (Ø50): 100 Adet / Pcs
- Ana Motor / Engine: 5,5 kW AC
- Kullanılabilir Masura Çapları / Core Diameter Range: Ø38 - Ø50 - Ø76 mm
- Sarılmış Rulo Çapı / Rewinded Product Diameter: Ø240 mm max.

MACHINERY



E - PSB 500 S

Otomatik Streç Dilimleme Ve Sarma Makinesi

Automatic Stretch Rewinder And Slicer Machine

- Tam otomatik sistem
- Otomatik masura deęiřtirme
- Otomatik tek tuřla Jumbo rulo saę-sol ayarı
- 7 inch dokunmatik PLC ekran (Omron)
- Sürücü motor: Omron
- Elektrik aksam: Schneider Electric
- Pnömatik sistem: Airtac
- Elektronik kenar kontrol sistemi
- Film ve masura sonu bitiř sensörü
- Kolay ayarlanabilen masura haznesi
- Rulo sarma sonunda sıcak tel ile kesim
- 2, 3, 4, 5 adet dilimleme özellięi

- Fully automatic system
- Automatic core rewinding and Exchange
- Automatic Jumbo roll right - left control unit with button
- 7 inch touch screen (Brand: Omron PLC)
- Motor dirve: Omron
- Switch gears: Schneider Electric
- Pneumatic system: Airtac
- Electronic edge control system
- Film and core presence sensor
- Easy to use core reservoir
- At the end of rewinding for a roll, cutting process with hot wire
- 2, 3, 4, 5 pcs slicing feature

TEKNİK ÖZELLİKLER / TECHNICAL SPECIFICATIONS

- Makine Hızı / Machine Speed: 1200 m/dk / (meter/min)
- Merdane Geniřlięi / Roller Width: 720 mm
- Kullanılabilir Jumbo Geniřlikleri / Jumbo Width Range: 300 - 520 mm
- Kullanılabilir Jumbo Aęırlıkları / Jumbo Weight Range: 75 kg max.

- Masura Haznesi / Core Reservoir (Ø50): 100 Adet / Pcs
- Ana Motor / Engine: 5,5 kW AC
- Kullanılabilir Masura Çapları / Core Diameter Range: Ø38 - Ø50 - Ø76 mm
- Sarılmış Rulo Çapı / Rewinded Product Diameter: Ø240 mm max.

MACHINERY

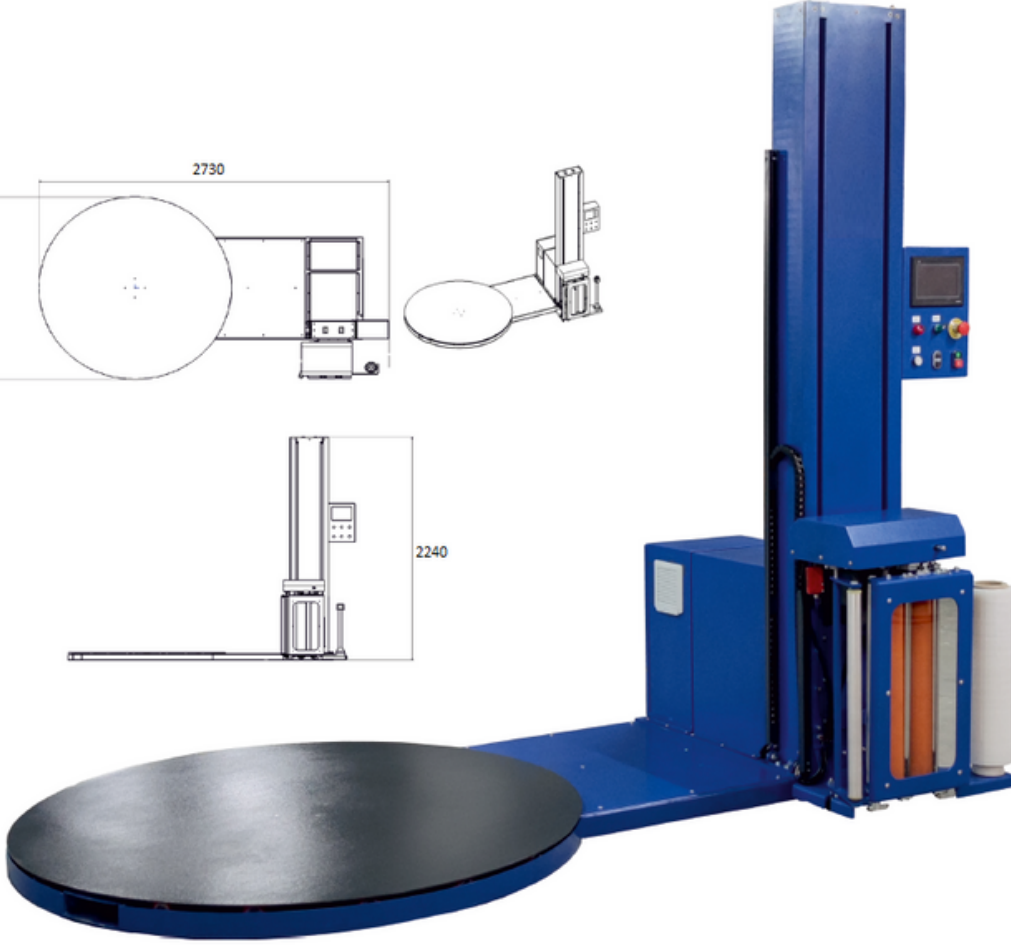
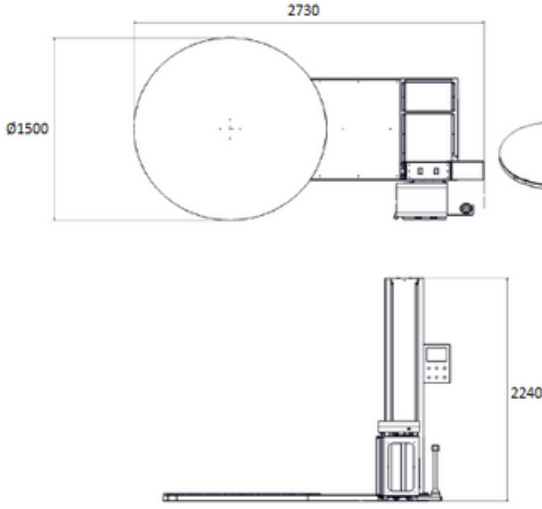

E - PST

Palet Sarma Makinesi

- İşleme başladığı noktada bitirme
- Hızlı ve kolay streç film değiştirme
- Sarım gerginliğini ekrandan ayarlama
- 7 inch dokunmatik PLC ekran (Omron)
- Üst sarım sayı ayarı
- Alt sarım sayı ayarı
- Manuel olarak tüm fonksiyonların kontrolü
- Tüm parametrelerin kaydedildiği 9 farklı program
- Streç film koptuğunda program durdurma ve kaldığı yerden devam etme
- Sarılan palet miktar sayıcı, numeratör

Pallet Wrapping Machine

- Wrapping completed at the start point
- Easy and fast stretch film replacement
- Wrapping tension setting from PLC
- 7 inch touch screen (Brand: Omron PLC)
- Top wraps setting
- Bottom wraps setting
- All functions can be controlled manually
- 9 user defined programs
- Program paused when the stretch film breaks and resumption of wrapping
- Counter for the amount of wrapped pallets

TEKNİK ÖZELLİKLER / TECHNICAL SPECIFICATIONS

- Film Kalınlığı / Film Thickness: 17 - 14 micron
- Tabla Dönme Hızı (max) / Turntable Speed: 4 - 18 d/dk (RPM)
- Max. Yük Taşıma Kapasitesi / Max. Loading Capacity: 2000 kg max.
- Standart Ön Gerdirme / Standard Pre-Stretch Range: %100 - %300

- Max. Sarım Yüksekliği / Max. Loading Height: 2100 mm max.
- Tabla Yerden Yüksekliği / Turntable Height: 76 mm
- 7 inch PLC Dokunmatik Ekran / 7 inches PLC Touch Screen
- Makine Ebatları / Machine Dimensions: 1500 x 2730 x 2240 mm (w-l-h)

MACHINERY

STRETCH FILM MACHINERY

- An amount of goods is grouped in order to be manouvered and shifted as a single package by using the palletizing.
- The grouping is performed on a stand called pallet that is often made of wood, which allows the handling and storage of the goods in warehouses and means of transport.
- Palletizing is important because it allows for various goods to be shipped at the same time using entire available space.
- Stretch film is the most used in ensuring and protecting of the palletized products, it is puncture-resistant and low cost. This type of film is used in practically every branch of the industry. It is used on a small scale as well as in facilities with modern and fully automated production lines.

The service includes;

- 1 year warranty
- Free technical support
- Installation
- Post warranty services

with the purchase of any of the machines introduced above.

Spare parts and free remote technical support are provided for the entire service life of the machine.

Satın alınan her bir makinede;

- 1 yıl garanti
- Ücretsiz teknik destek
- Kurulum
- Garanti sonrası hizmetler verilmektedir.

Yedek parça garantisi ve makinelerin tüm hizmet ömrü boyunca ücretsiz uzaktan teknik destek sağlanır.



EMTROI S ENDUSTRIYEL URUNLER
SANAYI VE TICARET LIMITED SIRKETI

ATATURK MAHALLESİ GIRNE CADDESİ NO.11/5
34758 ATASEHIR - ISTANBUL / TURKEY
WHATSAPP: +90 552 891 76 33
PHONE: +90 216 456 30 96
info@emtrois.com
www.emtrois.com